

Features

- High precision ADC, 4000 or 6000 counts, auto-range measurement
- AC true RMS output, measurement error<0.5% at 2kHz passband corner
- Built-in voltage divider, no external resistor divider needed
- Programmable multi-functional measurement network, support voltage, current, resistor, diode, transistor, open/short, temperature, capacitor, and frequency measurements
- Built-in charge pump, can measure 3V diode
- Multi-functional comparator with latch function
- 8 bits RISC ultra-low power MCU, 49 instructions and 6 stack levels. The MCU current consumption is 400uA typically at 3.3V and 2MHz operating clock rate. Standby current is 1.5uA at 32kHz clock, and less than 1uA at sleep
- 16k Bytes OTP for program storage, 256 Bytes SRAM for data storage
- 24 bit TMRA, TMRB, and TMRC arithmetic units for frequency and duty cycle calculations
- Low OTP programming voltage, can replace external EEPROM
- Flexible battery voltage detection range 2.0V~ 3.3V
- Abundant peripheral resources: UART, PWM, PFD, BUZ, and TIMER
- 18SEG×4COM LCD drive, ultra-low power consumption and high driving capability, programmable boost module to maintain luminance at low supply voltage, support grey scale adjustment. Support grey scale adjustment
- Every digital I/O port contain Schmitt trigger input and selectable pull up resistor
- Low voltage detection and power on reset circuit
- Operating voltage range: 2.4V~ 3.6V
- Operating temperature range: -40 °C~85 °C
- Built-in 8MHz and 32kHz RC oscillators

Description

The SD7501 is a SoC with built-in 24 bit ADC and 16k Bytes OTP memory. The IC was designed with ultra-low power technology. Operates at 3.3V supply and internal RC oscillator frequency, the total typical operating current is 2.0mA when the charge pump is off, and 3.0mA when it is on.

It has very rich peripheral resources: selectable regulated voltage source, flexible ADC setup, voltage booster, UART, TIMER with CAPTURE capability, PWM, PFD, and LCD driver.

The OTP can be programmed in situ and the 2.4V~3.6V programming voltage is generated internally. The OTP can be used in place of external EEPROM.

Three working modes are provided so users can select the optimum choice between speed and power. They are normal mode, standby mode, and sleep mode.

Applications

Manual or auto-range multimeter and similar measurement applications

Ordering Information

LQFP64 package

Pin Diagram and Descriptions

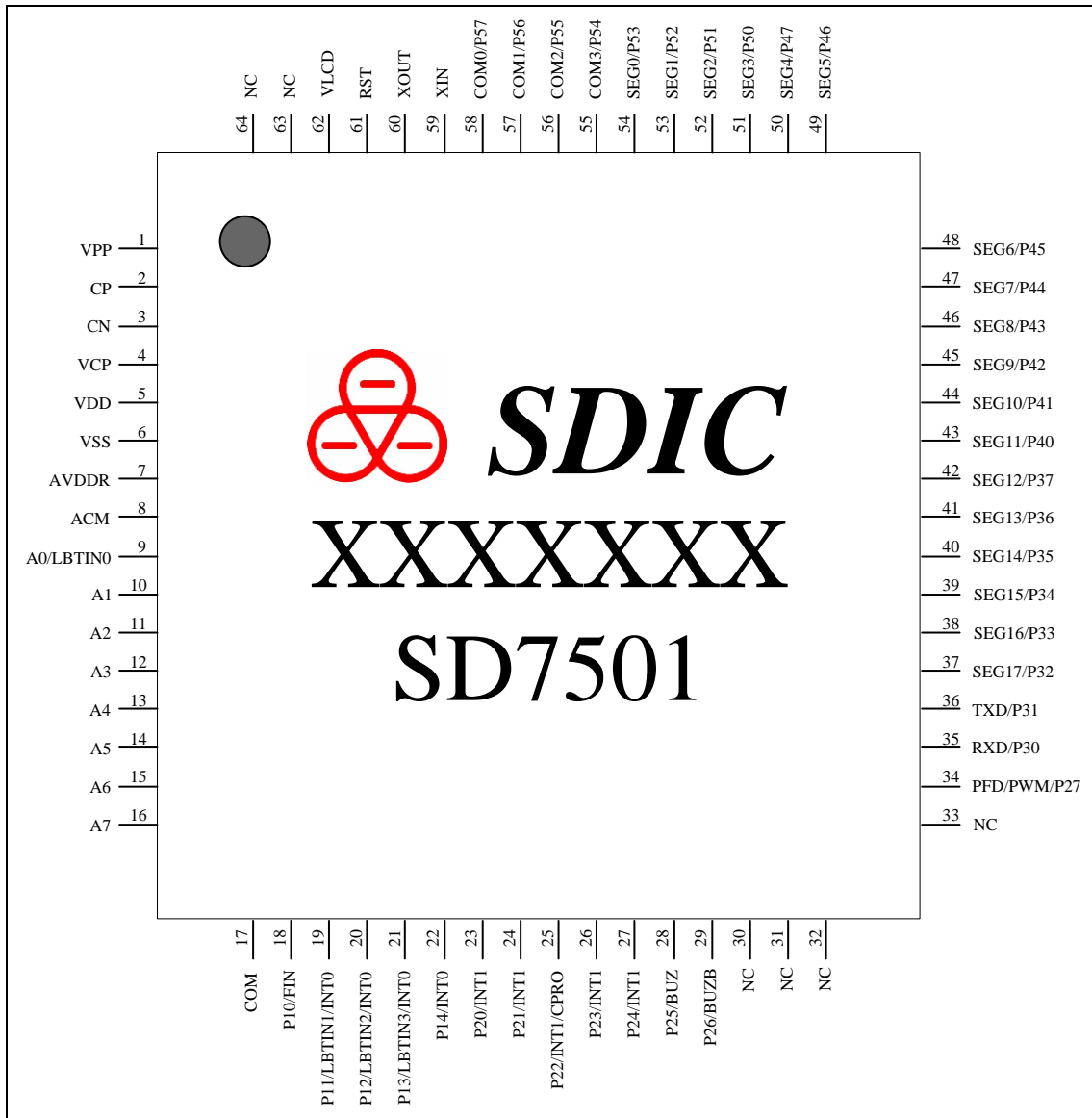

Figure 1. Pin out diagram

Table 1. Pin Descriptions

Pin No.	Pin Name	Attribute	Descriptions
1	VPP	Analog	OTP high voltage programming pin, connect 1uF capacitor to VSS
2	CP	Analog	charge pump's external capacitor connection pin
3	CN	Analog	charge pump's external capacitor connection pin
4	VCP	Analog	charge pump output voltage
5	VDD	Power	Power supply voltage, connect 0.1uF capacitor to VSS
6	VSS	Ground	Power ground
7	AVDDR	Analog	Internal LDO output for IC's analog module, connect 0.1uF to 10uF filter capacitor to VSS
8	ACM	Analog	ADC common mode voltage output, connect 0.1uF cap to VSS
9	A0/LBTIN0	Analog input	Analog signal inputs, each port has an independent register controlled pull-down resistor (default OFF), should set to ON for unused port. A0 can be set as LBTIN0 input
10-16	A1--A7	Analog input	Analog signal inputs, each port has an independent register controlled pull-down resistor (default OFF), should set to ON for unused port.
17	COM	Analog	Measurement circuit common ground, connect 0.1uF cap to VSS
18	P10/FIN	I/O	Digital port P10 or frequency measurement input
19	P11/INT0/LBTIN1	I/O	Digital port P11, external interrupt INT0, or low battery detect LBTIN1 input
20	P12/INT0/LBTIN2	I/O	Digital port P12, external interrupt INT0, or low battery detect LBTIN2 input
21-22	P13/INT0--P14/INT0	I/O	Digital ports P13-14 or external interrupt INT0
23-27	P20/INT1--P24/INT1	I/O	Digital ports P20-24 or external interrupt INT1
28	P25/BUZ	I/O	Digital port P25 or buzzer BUZ output
29	P26/BUZB	I/O	Digital port P26 or buzzer BUZB output
30-33	NC	NC	Leave floating, do not connect to any circuit
34	P27/PFD/PWM	I/O	Digital port P27 or PFD/PWM output
35	P30/RXD	I/O	Digital port P30 or UART's RXD port
36	P31/TXD	I/O	Digital port P31 or UART's TXD port
37-42	P32/SEG17--P37/SEG12	I/O	Digital port P32-37 or LCD segment SEG17-12
43-50	P40/SEG11--P47/SEG4	I/O	Digital port P40-47 or LCD segment SEG11-4
51-54	P50/SEG3--P53/SEG0	I/O	Digital port P50-53 or LCD segment SEG3-0
55-58	P54/COM3--P57/COM0	I/O	Digital port P54-57 or LCD COM3-0 During serial programming, Pin 37-40 serve as Data output, 2MHz clock input, Data input, and Data clock
59	XIN	Analog	Crystal oscillator pin
60	XOUT	Analog	Crystal oscillator pin
61	RST_B	I	External reset input, active low, internal 200k pull up resistor
62	VLCD	Analog	LCD driver power supply, internally connect to VDD or booster output through register setting, connect 1uF filter capacitor to VDD
63-64	NC	NC	Leave floating, do not connect to any circuit

Remark: All I/O ports Pnn have internal pull-up option (default OFF) and input hysteresis at 0.3VDD/0.7VDD.

Functional Block

Figure 2. Functional block diagram

Typical Application

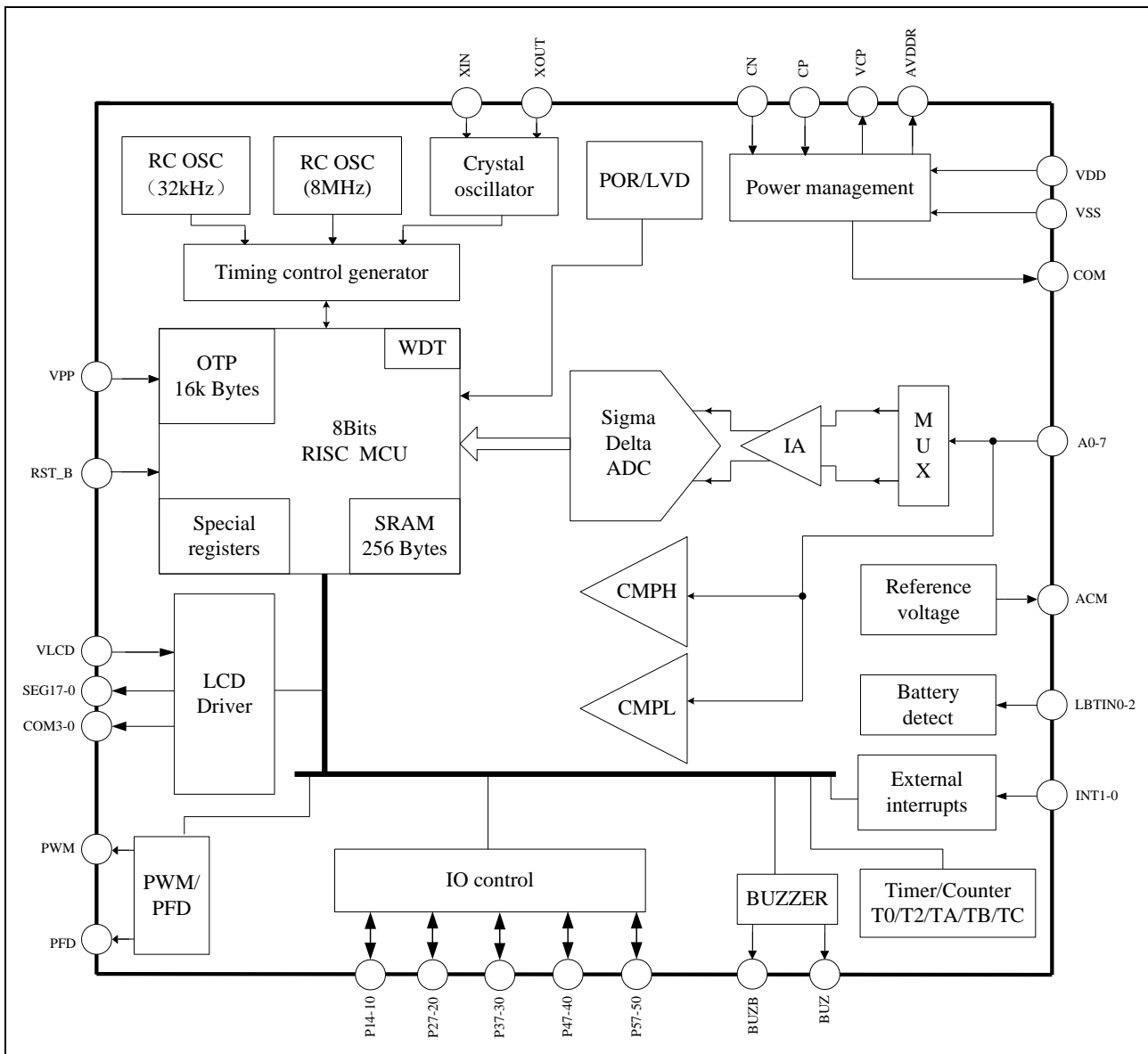
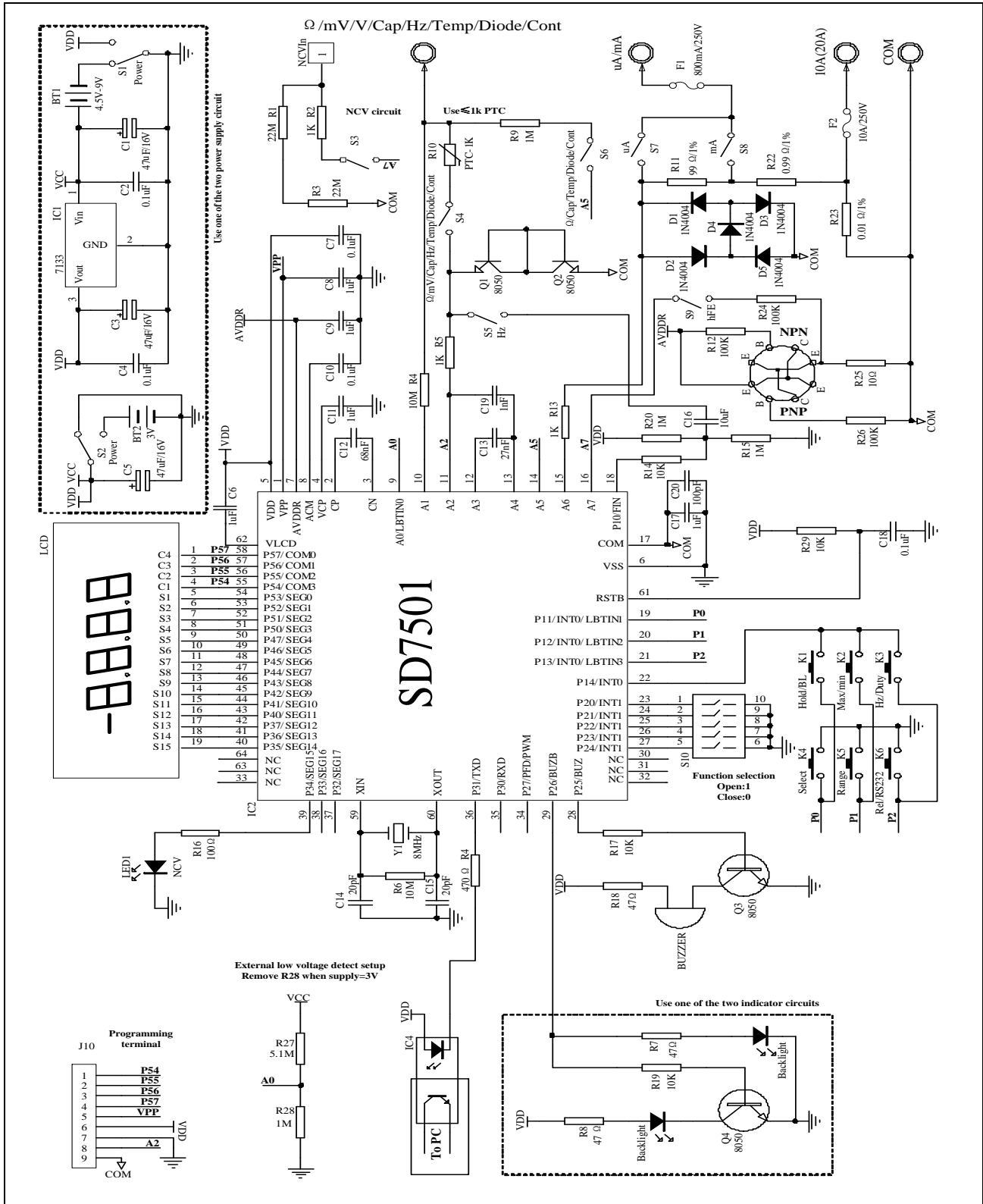

Figure 3. Multimeter typical application diagram

ADC Characteristics

Table 2. ENOB and voltage noise $V_{n_{rms}}$
(Gain=1, SINC3, VDD=3.3V, AVDDR=2.4V, VREF=1.2V, BUF1/BUF2 on)

ADC sampling rate = 512kHz								
OSR	128	256	512	1024	2048	4096	8192	16384
ENOB	16.80	17.92	18.34	18.82	19.23	19.24	19.65	19.73
$V_{n_{rms}}$ (uV)	21.03	9.69	7.25	5.19	3.91	3.86	2.91	2.76

ADC sampling rate = 1MHz								
OSR	128	256	512	1024	2048	4096	8192	16384
ENOB	16.82	17.76	18.46	18.78	19.19	19.45	19.64	19.90
$V_{n_{rms}}$ (uV)	20.77	10.84	6.66	5.32	4.01	3.34	2.95	2.46

Remark:

The above data are averages based on multiple ICs' measured results. Each IC contributes 1024 data points.

$ENOB = \log_2\left(\frac{FRS}{V_{rms}}\right)$, FRS is the Full Scale Voltage Range ($2 * V_{ref} / \text{Gain}$), V_{rms} is the rms Noise.

Electrical Specifications

Table 3. Absolute Maximum Ratings

Symbol	Parameter	Minimum	Maximum	Unit
T_A	Operating temperature	-40	+85	°C
T_S	Storage temperature	-55	+150	°C
V_{DD}	Supply voltage	-0.2	+4.0	V
V_{pp}	Programming voltage	-0.2	+7.5	V
V_{IN}, V_{OUT}	Digital input/output voltage	-0.2	$V_{DD}+0.3$	V
T_L	Reflow temperature profile	Per IPC/JEDECJ-STD-020C		°C

Remarks:

1. CMOS device can easily be damaged by electrostatics. It must be stored in conductive foam, and careful not to exceed the operating voltage range.
2. Turn off power before insert or remove the device.

Table 4. Electrical Specifications ($V_{DD}=3.3V, T_A=25^\circ C$)

Symbol	Parameter	Minimum	Typical	Maximum	Unit	Conditions/Remarks
VDD	Supply voltage	2.4	3.3	3.6	V	Analog modules operating voltage
		2.0	3.3	3.6	V	Digital modules and MCU operating voltage
FOSC	Operating frequency	0.016	2	4	MHz	FOSC must be 2MHz when read/write tables in OTP
IHRC	Internal high frequency RC oscillator	7.9	8	8.1	MHz	Frequency after calibration
ILRC	Internal low frequency RC oscillator	24	32	40	kHz	Frequency after calibration
HXT	External high frequency crystal oscillator	1	--	8	MHz	

LXT	External low frequency crystal oscillator	16	32.768	--	kHz	
IDD1	Operating current 1	--	2.0	3.0	mA	Internal RC oscillator frequency quartered for MCU Analog modules active
IDD2	Operating current 2	--	1.5	2	uA	32kHz internal RC oscillator for MCU MCU at standby mode Analog modules inactive
IDD3	Operating current 3	--	0.2	1	uA	MCU at sleep mode Analog modules inactive
Fsam	ADC sampling rate	--	500	1000	kHz	
OSR	Over sampling rate	128	--	16384		
NFbit	Noise free bits ¹	--	16	--	bits	Gain=128, input FSR=±4mV
BW	AC measurement bandwidth		2		kHz	Measurement error<0.5%
VINdif	PGIA differential input range	-Vref/	--	Vref/	mV	1X gain
		-Vref/2	--	Vref/2		2X gain
		-Vref/4	--	Vref/4		4X gain
		-Vref/8	--	Vref/8		8X gain
		-Vref/16	--	Vref/16		16X gain
		-Vref/32	--	Vref/32		32X gain
		-Vref/64	--	Vref/64		64X gain
		-Vref/128	--	Vref/128		128X gain
VIN	PGIA input voltage range ²	-0.3	--	AVDDR		1X gain and buffer is off
		0.3	--	AVDDR-0.7		1X gain and buffer is on, or gain≠1
V _{n_{rms}}	RMS noise	--	2.76	--	uV _{rms}	1X gain and OSR=16384
V _{acm}	ACM voltage output	--	1.2	--	V	
I _{acmSour}	ACM current source	--	1	--	mA	
I _{acmSink}	ACM current sink	--	1	--	mA	
PSR _{acm}	ACM PSR	--	100	--	uV/V	
V _{avddr}	AVDDR voltage output	--	2.4	--	V	AVDDRX[2:0]=000
		--	VCP	--		AVDDRX [2:0]=001 VCP=charge pump voltage
		--	2.9	--		AVDDRX [2:0]=010
		--	3.3	--		AVDDRX [2:0]=011
			3.6			AVDDRX [2:0]=100
			3.9			AVDDRX [2:0]=101
			reserve			AVDDRX [2:0]=110/111
I _{avddr}	AVDDR current	--	10	--	mA	
POR	Power On Reset voltage	--	2.0	--	V	
LVD	Low Voltage Detect reset voltage	--	1.9	--	V	

THlbt	LVD hysteresis	--	200	--	mV	
Vlcd	LCD charge pump output voltage	--	2.1	--	V	VLCDX[2:0]=000
		--	2.3	--		VLCDX[2:0]=001
		--	2.5	--		VLCDX[2:0]=010
		--	2.7	--		VLCDX[2:0]=011
		--	2.9	--		VLCDX[2:0]=100
		--	3.1	--		VLCDX[2:0]=101
		--	3.3	--		VLCDX[2:0]=110
		--	3.5	--		VLCDX[2:0]=111
Ilcd	LCD charge pump current ³	--	--	500	uA	
Digital I/O parameter						
IOH	High output current source	--	3	--	mA	VOL=VDD-0.3V, PTxSR=0
		--	12	--		VOL=VDD-0.3V, PTxSR=1
IOL	Output low current sink	--	3	--	mA	VOH=0.3V, PTxSR=0
		--	12	--		VOH=0.3V, PTxSR=1
VIH	Input high voltage	0.7VDD	--	--	V	
VIL	Input low voltage	--	--	0.3VDD	V	
VOH	Output high voltage	VDD-0.3	--	--	V	
VOL	Output low voltage	--	--	VSS+0.3	V	
Rpu	Pin pull up resistance	--	200	--	kΩ	VDD = 3.0

Note:

1. Noise free bits and effective resolution are both related to the signal's full scale range. Its peak to peak or rms noise plays the decisive role.
2. The signal input range is limited by the differential signal input range and the absolute voltage at the input terminals. The first one is the real signal input range. It is affected by the PGIA gain and the ADC voltage reference choice. The second one includes both differential and common mode components and is mainly limited by the circuit.
3. The charge pump driving capability is related to the choice of capacitor and the operating frequency.

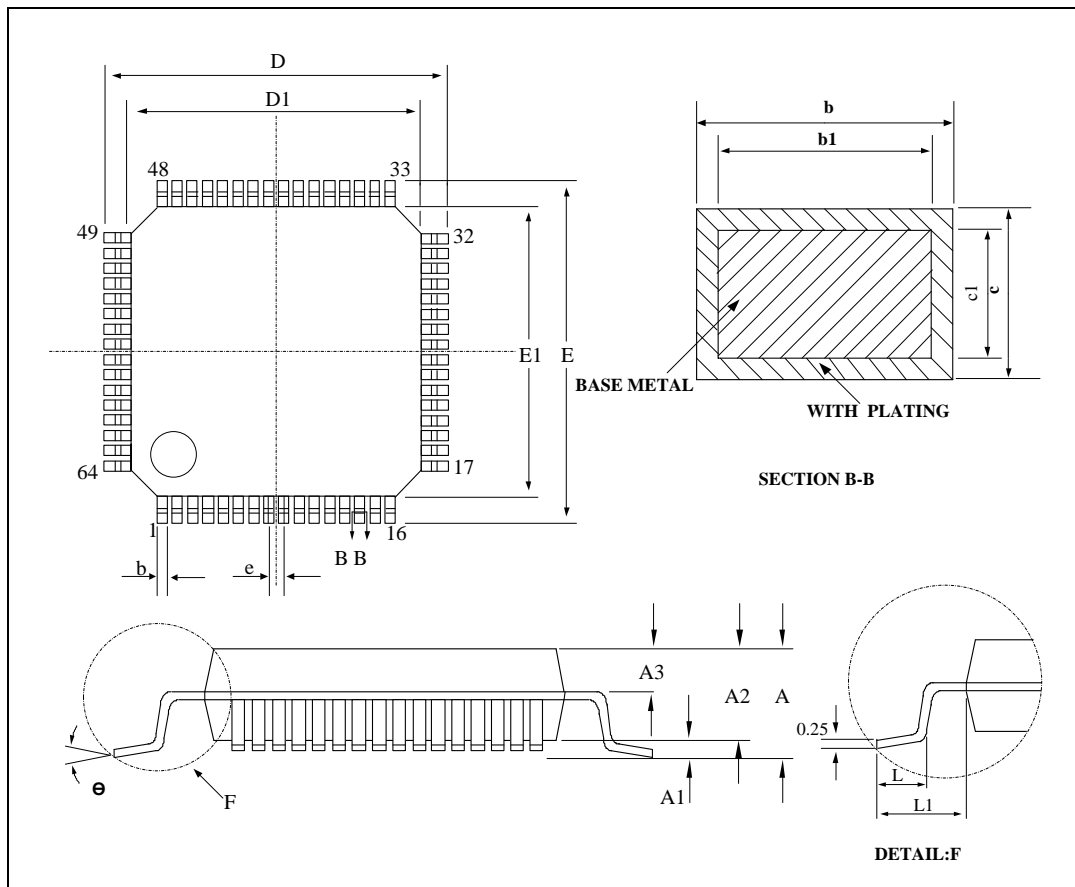
Packaging Information

Dimensions: mm

Symbol	Min.	Nom.	Max.
A	—	—	1.60
A1	0.05	—	0.20
A2	1.35	1.40	1.45
A3	0.59	0.64	0.69
b	0.19	—	0.27
b1	0.18	0.20	0.23
c	0.13	—	0.18
c1	0.12	0.13	0.14
D	11.80	12.00	12.20
D1	9.90	10.00	10.10
E	11.80	12.00	12.20
E1	9.90	10.00	10.10
e	0.50BSC		
L	0.45	—	0.75
L1	1.00BSC		
θ	0	—	7

Figure 4. LQFP64 mechanical specification